

# COMMERCIAL DATA SHEET

## Quadra Sparkling 4100 MMT

# Billi®

### Billi Quadra Sparkling 4100 with Gooseneck Multifunction Mixer Tap

The Quadra Sparkling is the ultimate in modern design and filtered drinking water appliances delivering instant boiling and chilled filtered water, with the added luxury of sparkling water.

Utilising underbench ice bank technology to enhance capacity and recovery, the Quadra Sparkling has a commercial capacity and is suitable for any environment.

The Good Design Award Winning Multifunction Mixer tap complements the multifunctional approach of Billi's Quadra Sparkling range perfectly, negating the requirement for an additional domestic supply mixer tap while providing a sleek solution to dispensing filtered water.



BOILING



CHILLED



SPARKLING



Up to 100

Multifunction Mixer Tap

Quadra Sparkling Under-Bench Unit



### Features



SAFE TO OPERATE



ECO-INTELLIGENCE TECHNOLOGY



ADJUSTABLE CHILLED TEMPERATURE



ADJUSTABLE SPARKLING LEVEL



ICE BANK TECHNOLOGY



CHOICE OF DISPENSER DESIGNS



HACCP CERTIFIED



ITALO-AUSTRALIAN PARTNERSHIP



AWARD WINNING DESIGN

# Australian Made Boiling Unit \* Italian Design & Made Sparkling Unit

## PRODUCT SPECIFICATIONS

Water type	Product code	Model name	Dispenser	Suggested no. of people	Boiling water delivery (cups per hour)*	Chilled & Sparkling water delivery (cups per hour)	Power supply (amps)
BOILING CHILLED SPARKLING	906100G	Quadra Sparkling 4100	Multifunction Mixer Tap	Up to 100	Up to 220	200	1 x 10 1 x 15

\* Based on a set volume of water being drawn every 30 seconds at an inlet temperature of average 21°C. Each cup equivalent to 170ml. Usage patterns and draw-off methods can impact recovery.

### Accessories

**990726** - Tubing Extension Kit for Sparkling unit - 2mtrs

### Finishes

Standard Finishes

CH - Chrome	BR - Brushed
MB - Matte Black	MW - Matte White

Special Order Finishes

RG - Rose Gold	BRG - Brushed Rose Gold
GM - Gun Metal Grey	UB - Urban Brass

Add the relevant Finishes Code to the Product SKU to finalise your specification eg 906100GMB

# TECHNICAL DRAWING & INSTALLATION REQUIREMENTS

## PRODUCT DIMENSIONS

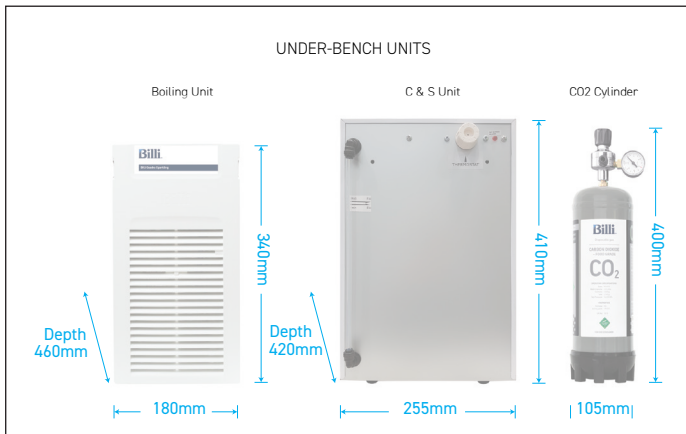
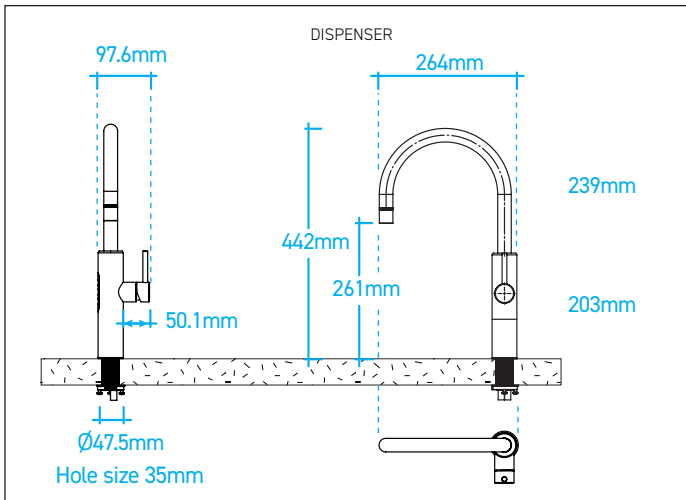

## PREFERRED INSTALLATION LAYOUT

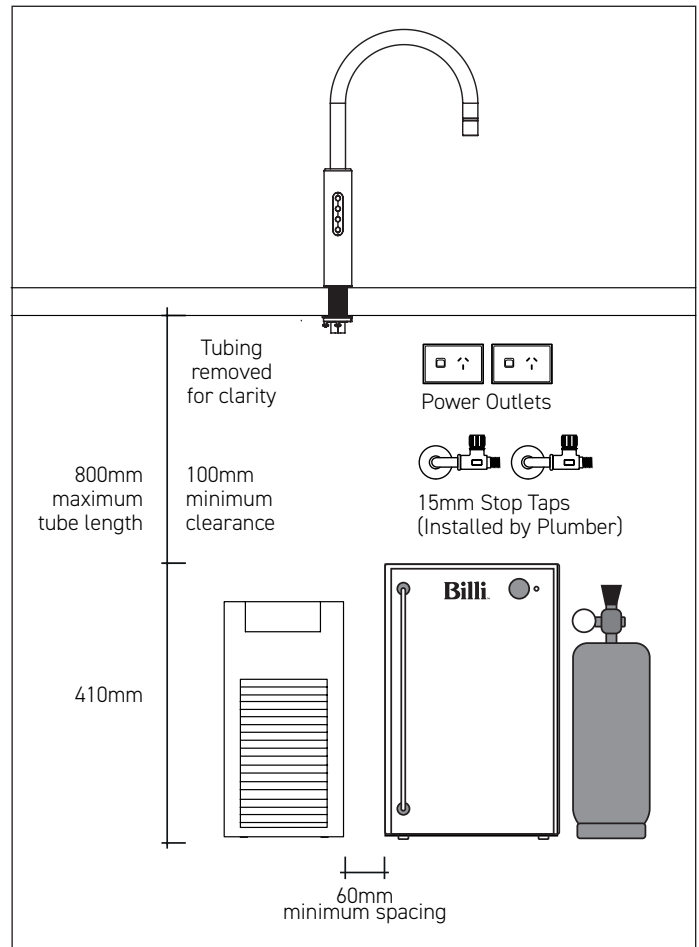

### WATER SUPPLY

Domestic Cold and Hot mains supply is required via separate 1/2" BSP (15mm) stop-taps with male threads. These should be pre-installed in an easily accessible position. Water supply must be microbiologically safe to drink, with a minimum dynamic water pressure of 250kPa and a maximum of 1000kPa.

### POWER SUPPLY

A standard 10 amp power outlet plus an additional standard 15 amp outlet are required. Both outlets located no further than 1000mm from the underbench unit. The system is supplied with a 1 metre flex cord and plug.

### FILTRATION

Billi's range of premium filters utilise BWT's unique Fibron X technology. Billi's filter range provides superior taste, water quality, consistent filter life and peace of mind when it comes to hygiene.

Filter supplied: 994051 (5 micron). Replacement filters available: 994052 (0.2 micron), 994054 (HSD option), 994056 (Sediment only) and 994060 (0.2 micron Sediment Only).

### CERTIFICATIONS

Every Billi drinking water appliance is manufactured under a certified quality control system. All Billi commercial range models have been tested and comply with all required standards including: Watermark: WM-022690; Tested to ATS5200.105 and AS/NZ 4020; ISO 9001:2015, QEC 11627; AS1428; HACCP: PE-872-WAT-1-02; WELL Cornerstone Member; WELS 5 Star Rating: WM-021914.

### CO<sub>2</sub> Cylinder

The CO<sub>2</sub> gas cylinder supplied must be secured in a suitable location. Each cylinder contains 1100g of CO<sub>2</sub> and should be installed in a well ventilated area. Each cylinder will provide between 200-350L of sparkling water depending on the unit settings. The MSDS is available on [www.billi.com.au](http://www.billi.com.au) for a complete list of specifications and warnings. Replacement gas cylinders are available from Billi. CO<sub>2</sub> Cylinder - single 996911 or double 996912

### WARRANTY

The Billi Quadra Sparkling Range is covered by a comprehensive 2 year warranty on all parts and labour.

# Billi



Billi Australia Pty Ltd

P 1800 812 321  
W [www.billi.com.au](http://www.billi.com.au)

Billi New Zealand Ltd T/As Merquip

P 0800 636 0 636  
W [www.merquip.co.nz](http://www.merquip.co.nz)

visit us at



Share your content



Product reviews

Customer support

Warranty registration