

COMMERCIAL DATA SHEET

OmniOne Pro60 MMT



Billi OmniOne Pro60 with Gooseneck Multifunction Mixer Tap

The OmniOne Pro60 is the latest iteration of multifunction filtered drinking water appliances from Billi. The intersection of genuine innovation and sustainable design, OmniOne integrates Billi's renowned water-cooling and energy reclaim technologies into a single space-saving under bench control module. With a 30% uplift in performance, whisper quiet in operation, ergonomic and acutely focused on the wellness & hygiene of it's users, the OmniOne Pro60 range is the ultimate inclusion to the modern workplace or facility.

The Good Design Award Winning Multifunction Mixer tap complements the space saving and multifunctional approach of Billi's OmniOne range perfectly, negating the requirement for an additional domestic supply mixer tap while providing a sleek solution to dispensing filtered water.

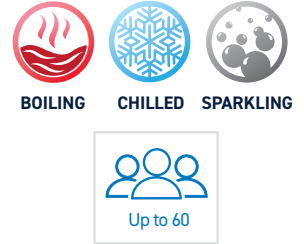

Multifunction Mixer Tap



OmniOne Pro60 Under-Bench Unit



Features



PRODUCT SPECIFICATIONS

Water type	Product code	Model name	Dispenser	Suggested no. of people	Boiling water delivery (cups per hour)*	Chilled & Sparkling water delivery (cups per hour)	Power supply (amps)
BOILING CHILLED SPARKLING	926060G	OmniOne Pro60	Multifunction Mxer Tap	Up to 60	180	220	1 x10

* Based on a set volume of water being drawn every 30 seconds at an inlet temperature of average 21°C. Each cup equivalent to 170ml. Usage patterns and draw-off methods can impact recovery.

Accessories

990726 - Tubing Extension Kit for Sparkling unit - 2mtrs

Finishes

Standard Finishes

CH - Chrome	BR - Brushed
MB - Matte Black	MW - Matte White

Special Order Finishes

RG - Rose Gold	BRG - Brushed Rose Gold
GM - Gun Metal Grey	UB - Urban Brass

Add the relevant Finishes Code to the Product SKU to finalise your specification eg 926060LMB

TECHNICAL DRAWING & INSTALLATION REQUIREMENTS

PRODUCT DIMENSIONS

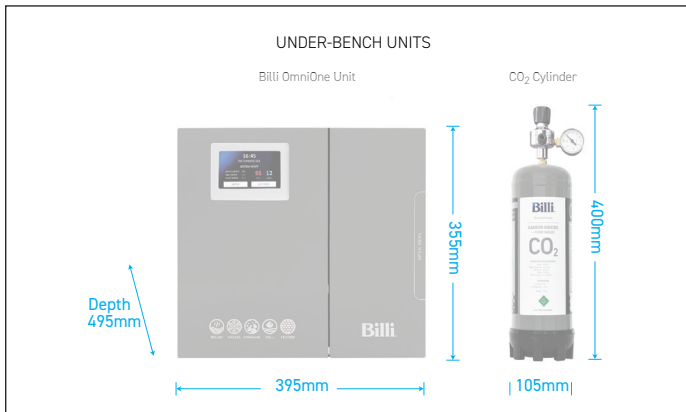
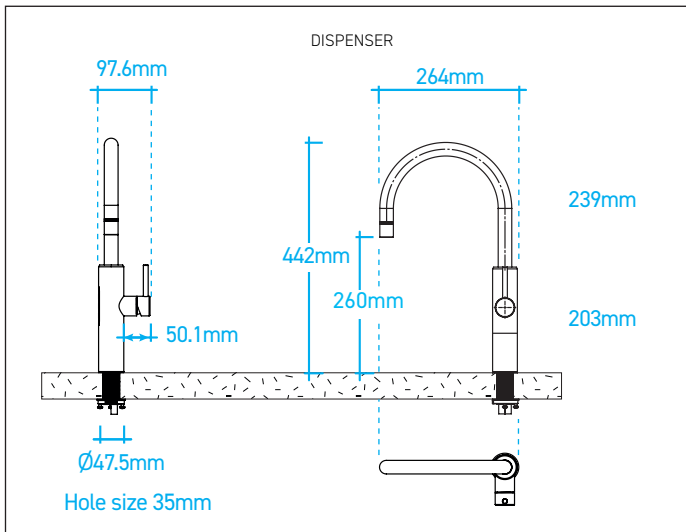

PREFERRED INSTALLATION LAYOUT

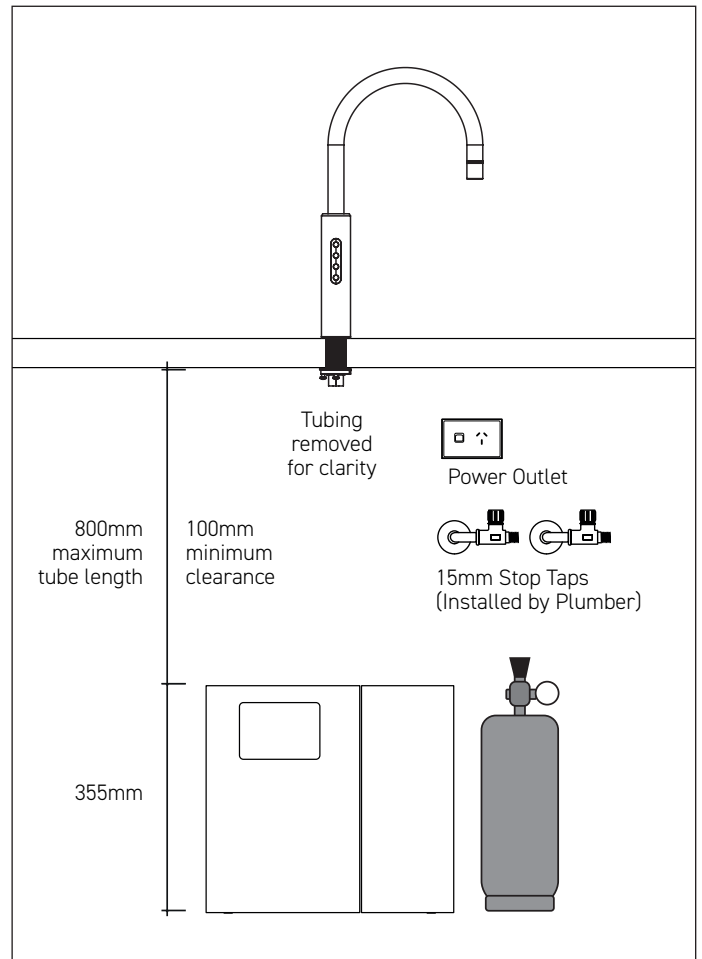

WATER SUPPLY

Domestic Cold and Hot mains supply is required via separate 1/2" BSP (15mm) stop-taps with male threads. These should be pre-installed in an easily accessible position. Water supply must be microbiologically safe to drink, with a minimum dynamic water pressure of 250kPa and a maximum of 1000kPa.

POWER SUPPLY

A standard 10 amp power outlet is required, located no further than 1000mm from the underbench unit. The system is supplied with a 1 metre flex cord and plug.

FILTRATION

Billi's range of premium filters utilise BWT's unique Fibron X technology. Billi's filter range provides superior taste, water quality, consistent filter life and peace of mind when it comes to hygiene.

Filter supplied: 994051 (5 micron). Replacement filters available: 994052 (0.2 micron), 994054 (HSD), 994055 (XPHSD), 994056 (Sediment only) and 994060 (0.2 micron sediment only).

CERTIFICATIONS

Every Billi drinking water appliance is manufactured under a certified quality control system. All Billi commercial range models have been tested and comply with all required standards including: Watermark: WM 021525; ISO 9001:2015, QEC 11627; Tested to ATS5200.105 and AS/NZ 4020; WELL Cornerstone Member; WELS 5 Star Rating: WM-021914.

CO₂ Cylinder

The CO₂ gas cylinder supplied must be secured in a suitable location. Each cylinder contains 1100g of CO₂ and should be installed in a well ventilated area. Each cylinder will provide between 200-350L of sparkling water depending on the unit settings. The MSDS is available on www.billi.com.au for a complete list of specifications and warnings. Replacement gas cylinders are available from Billi. CO₂ Cylinder - single 996911 or double 996912.

WARRANTY

The Billi OmniOne Range is covered by a comprehensive 3 year warranty on all parts and labour.

Billi®



Billi Australia Pty Ltd

P 1800 812 321
W www.billi.com.au

Billi New Zealand Ltd

P 0800 636 0 636
W www.billi.co.nz

visit us at

