

# COMMERCIAL DATA SHEET - Straight Wall Mount Soap Sensor



## Billi Straight Wall Mount Soap Sensor Dispenser

Billi's contactless soap dispenser range uniquely features it's infrared sensor built into the spout. This sensor automatically detects hand movement in the dispensing zone and has a configurable run time of between 0.5 seconds and up to 10 seconds, reducing wastage.

The soap dispenser range is ideal for use in food preparation, healthcare, aged care, residential bathrooms, childcare, schools and universities, and commercial washrooms.



Straight Wall Mount Soap Sensor Dispenser



Soap Reservoir Unit



## Features



CONTACTLESS DISPENSING



SENSOR ACTIVATED



USER FRIENDLY & ERGONOMIC DESIGNED



RANGE OF FINISHES



MAINS OR BATTERY POWER



SUITABLE USE WITH LIQUID SOAP

## PRODUCT SPECIFICATIONS

Water type	Product code	Model name	Reservoir size	Max dispense time
<p>SOAP    SENSOR</p>	982412	Straight Wall Mount Soap Sensor Dispenser	1700ml	10 seconds

## Accessories

**948105** – Back of wall PVC install kit

## Finishes

Standard Finishes

CH - Chrome

BR - Brushed

MB - Matte Black

Special Order Finish

UB - Urban Brass

Add the Finish code to the Product Code to finalise your specification, eg. 982412CH

# TECHNICAL DRAWING & INSTALLATION REQUIREMENTS

## PRODUCT DIMENSIONS

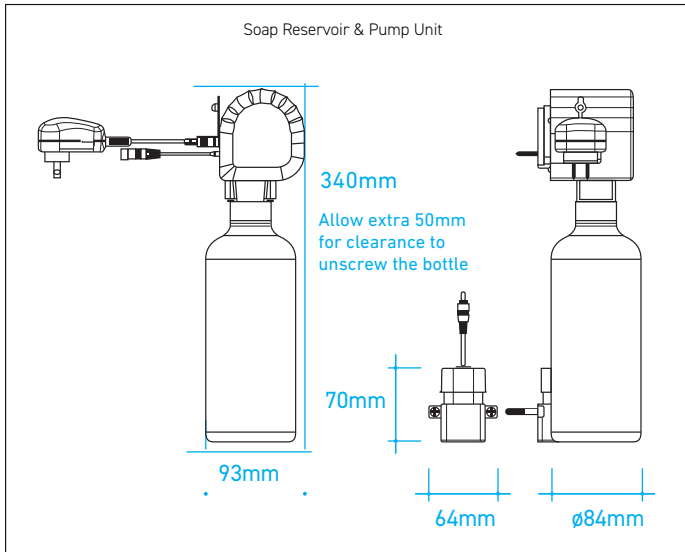
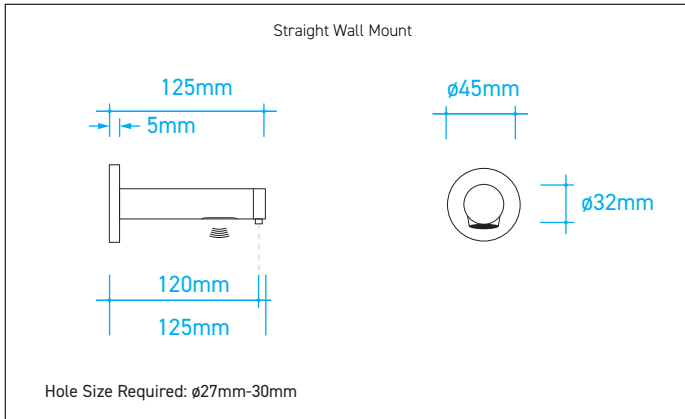

## PREFERRED INSTALLATION LAYOUT

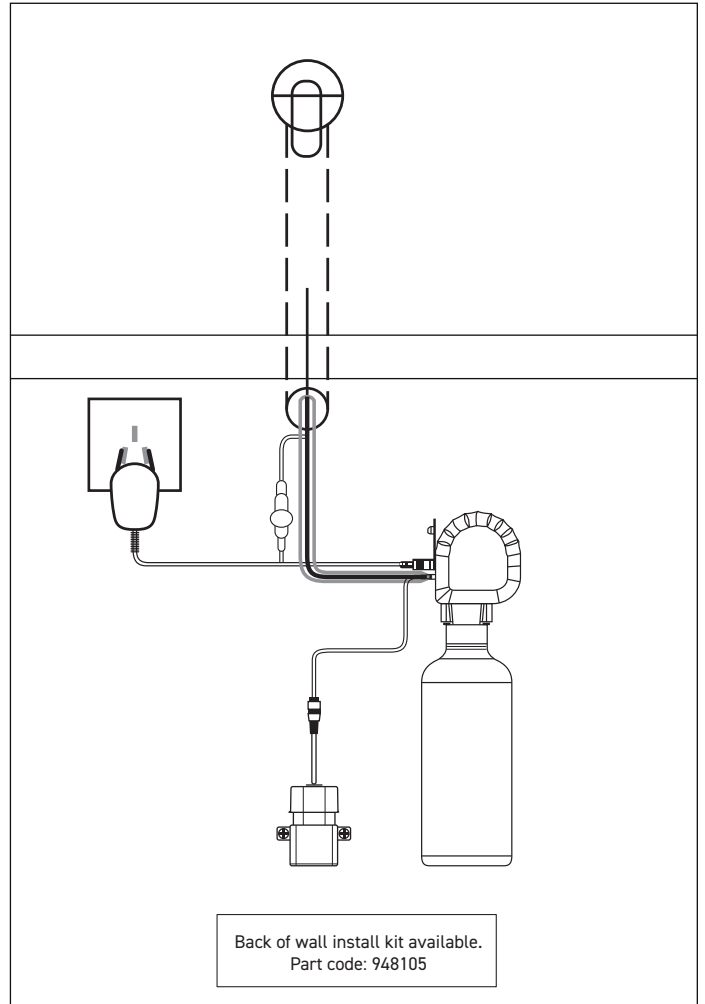

### POWER SUPPLY

The Billi sensor tap is supplied with battery or mains power packs.

Battery: 6V DC / 4 x 1.5 AA batteries (not supplied).

Mains: 240V 10 amp GPO.

The control box must be fitted no more than 1100mm from the outlet.

Transformer power supply lead is 1300mm long. All Billi sensor taps

are supplied with wall plugs and screws.

### CERTIFICATIONS

The Billi Sensor Soap Dispensers are manufactured under a certified quality control system. Billi Sensor Soap Dispensers have been tested and comply to:

ISO9001:2015, QEC 11627;

WELL member mark;

Compliant to AS1428.

### WARRANTY

The Billi Washroom Range is covered by a comprehensive 12 month warranty on all parts and labour.

# Billi™

Billi Australia Pty Ltd  
42 Lucknow Crescent,  
Thomastown, Victoria  
3074 Australia

**P** 1800 812 321  
**F** +61 3 9469 0499  
**W** www.billi.com.au

visit us at



Designed and manufactured in Australia to the highest quality standards